



# AVILLE Residence

MBW COVE





SP SAM PROPERTY  
SDN BHD



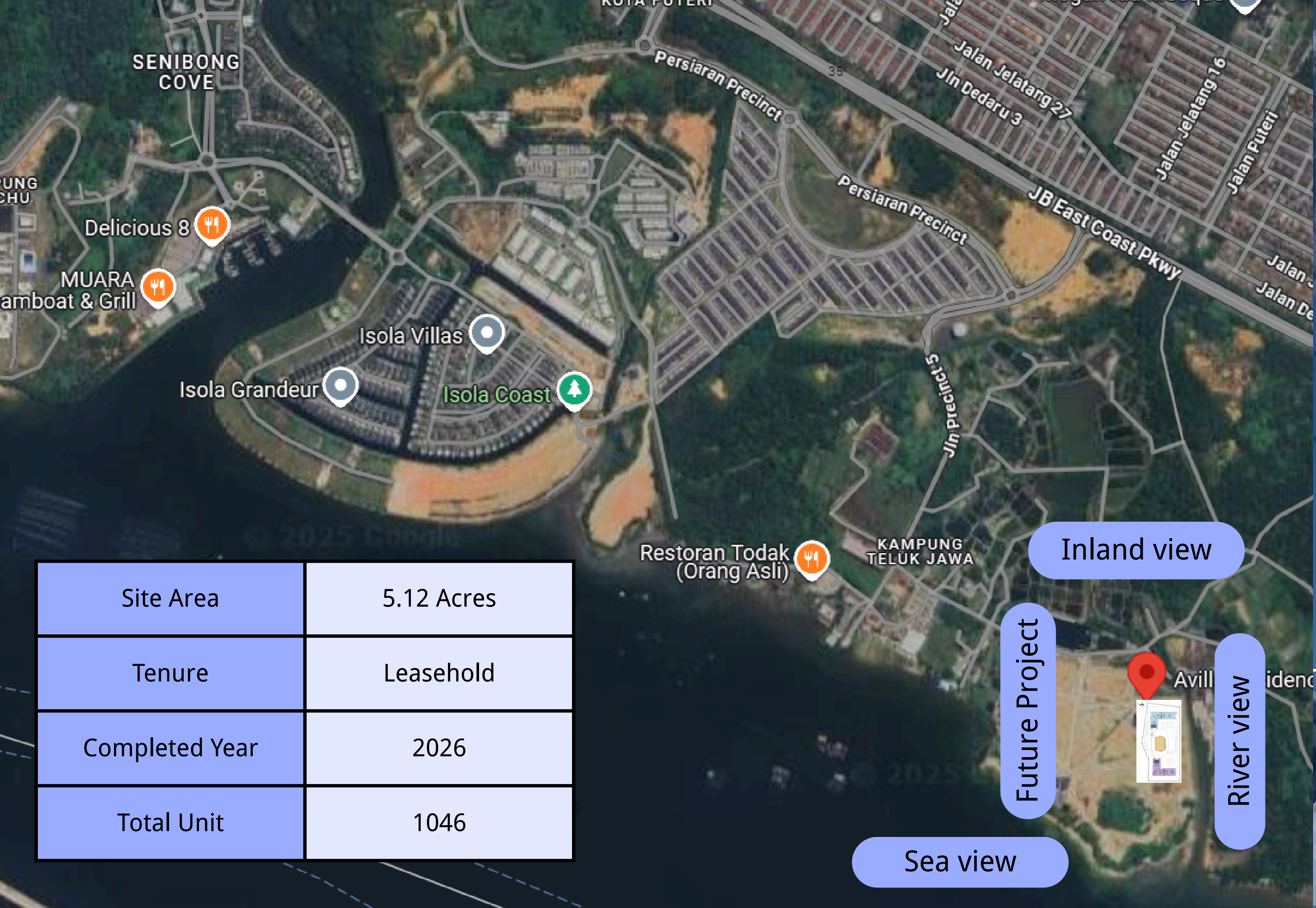

Site Area	5.12 Acres
Tenure	Leasehold
Completed Year	2026
Total Unit	1046





Future Development

Future Development

Future Development

Future Development

**Aville Residences**  
Serviced Apartment  
1,046 units

Future Development

**Kompleks PIJ Holdings**

**Residensi Perbadanan Islam Teluk Permata**  
RMMJ Apartment  
105 units

**PermataBiz**  
Single-storey Shop Office  
25 units

**Taman Teluk Permata**  
Double-storey Terrace House  
63 units



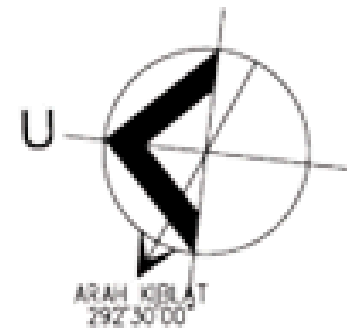
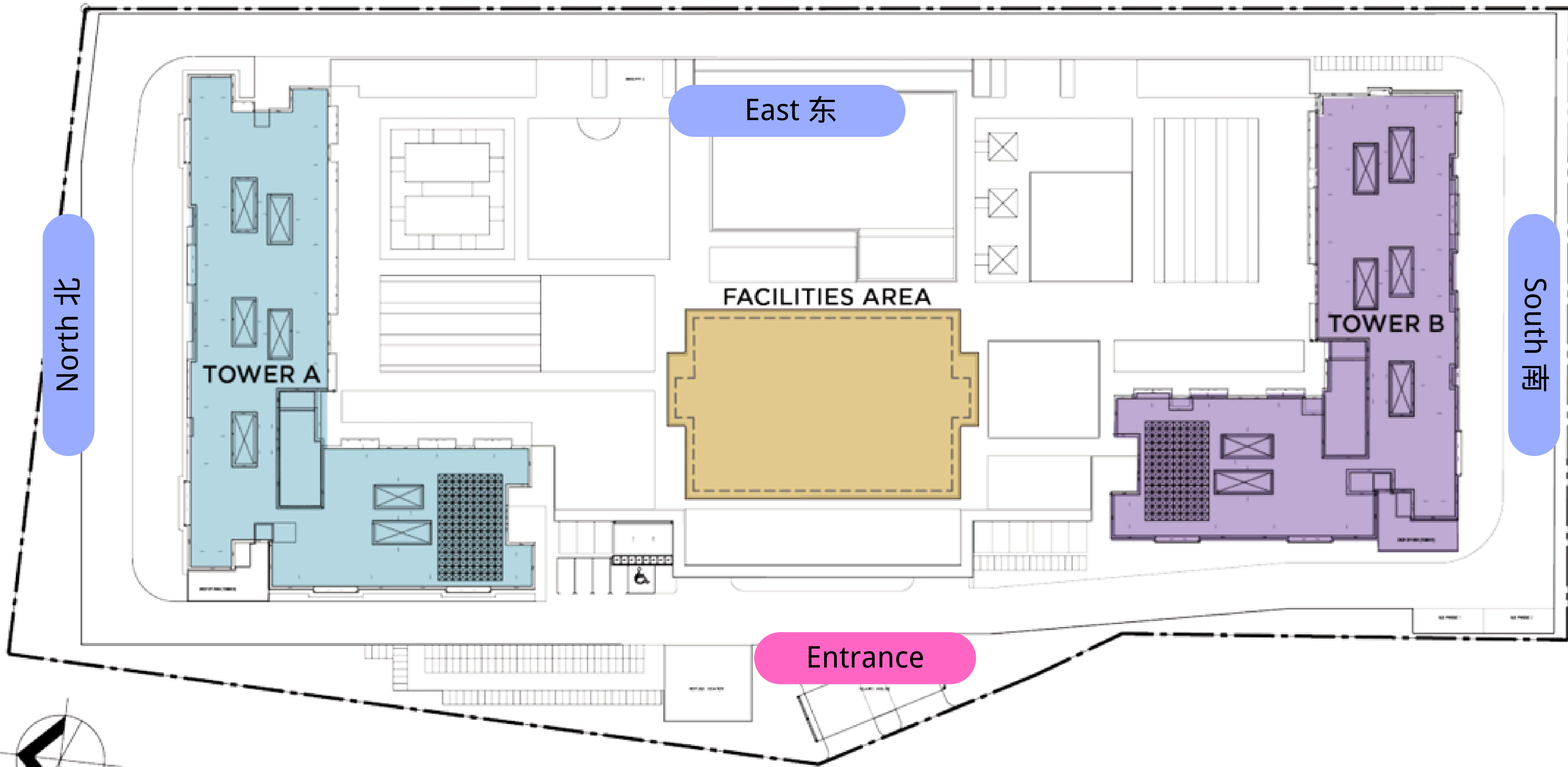

# TYPICAL FLOOR PLAN

Level 8 - 30

## TOWER A

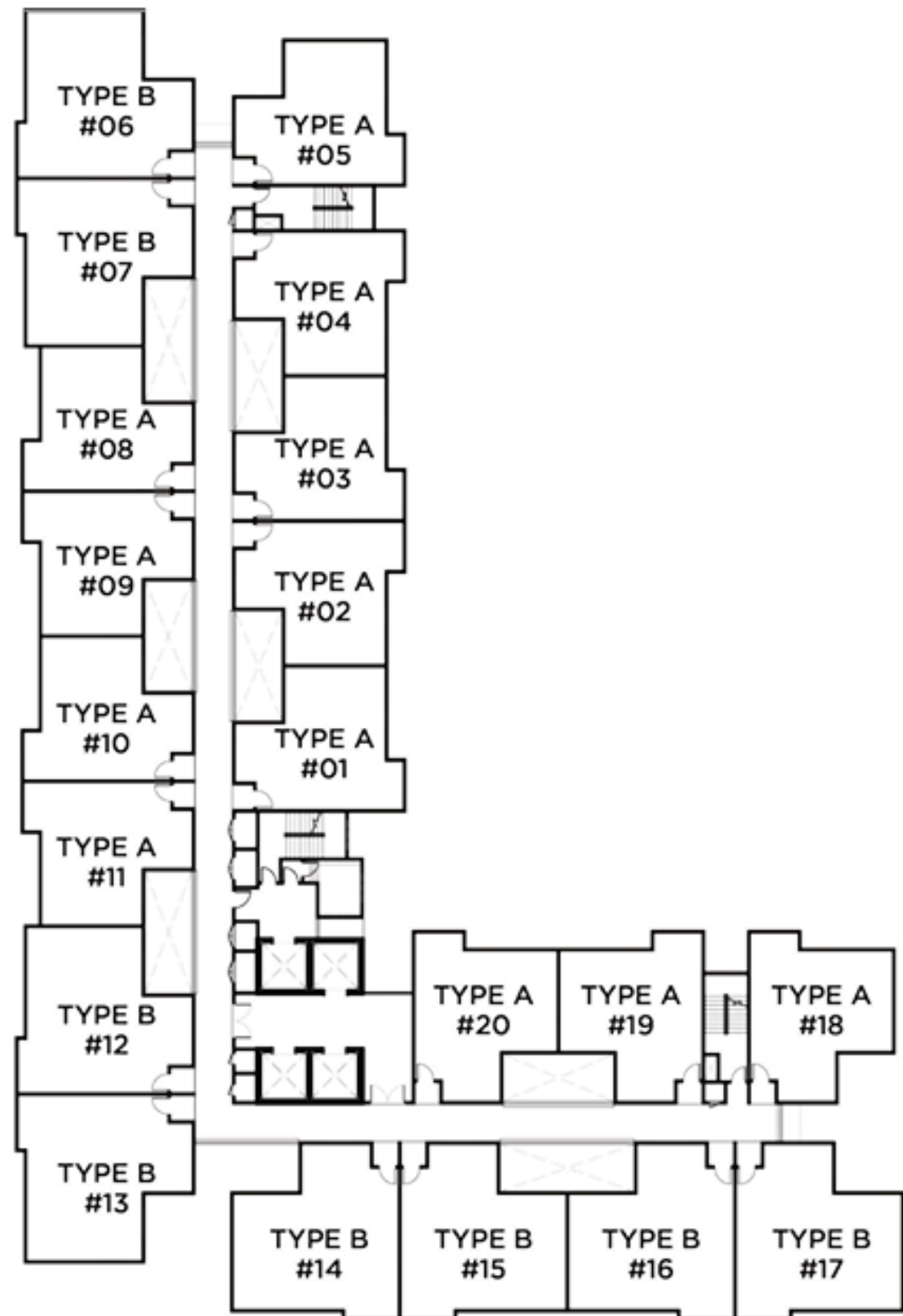

## TOWER B

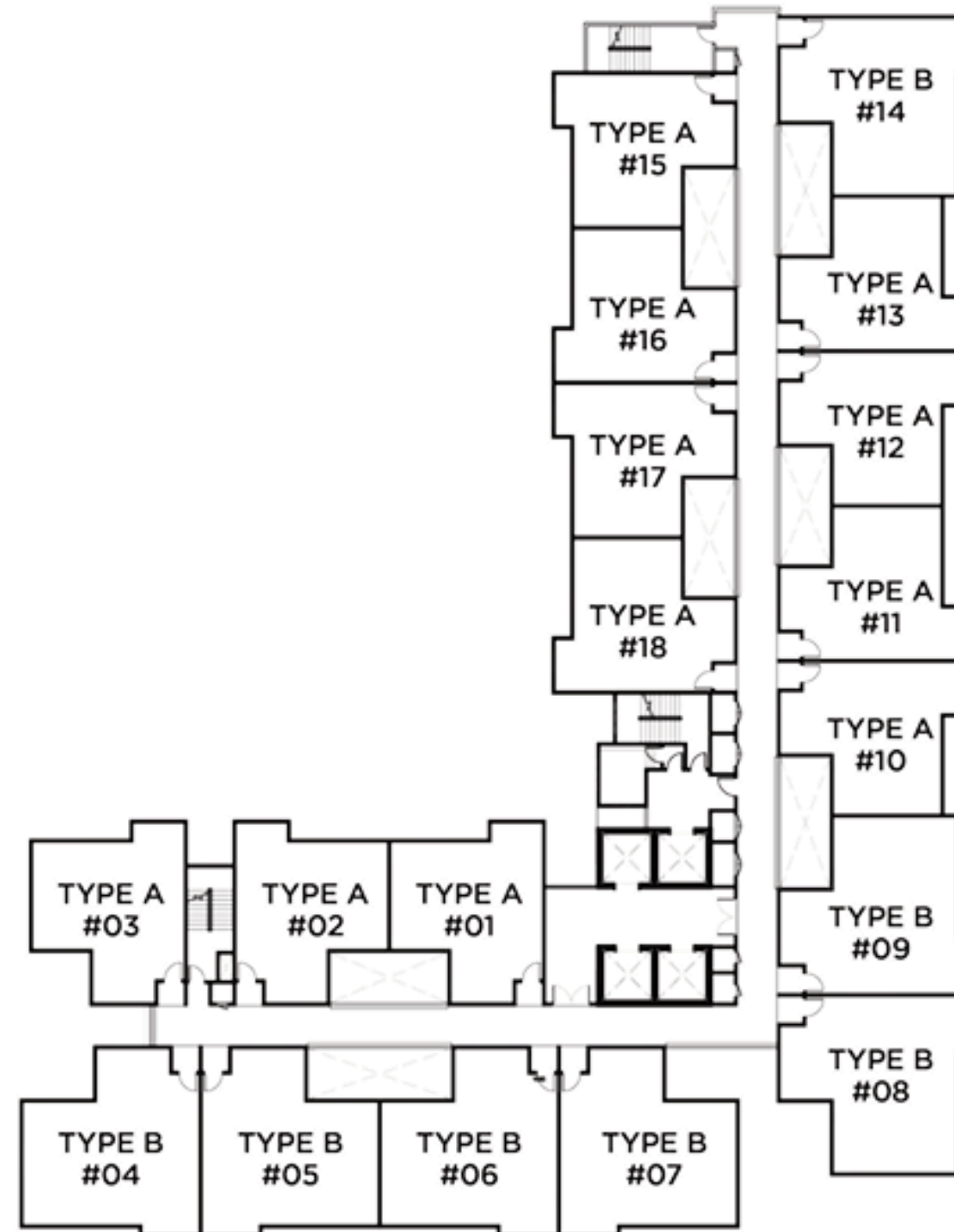

No. of Level	30 Level
Unit per Floor	Tower A - 20 units Tower B - 18 units
No. of Lift	4
Carpark Level	Level 1- 6
Facilities Floor	Level 7
No. of Carpark	Type A - 1 carpark Type B - 2 carpark
No. of Type	Type A 1+1 B 2B 658 sqft TYPE A PES 998 sqft Type B 3B 2B 853 sqft

# TYPICAL FLOOR PLAN

Level 1 - 6

## TOWER A

12 units per floor

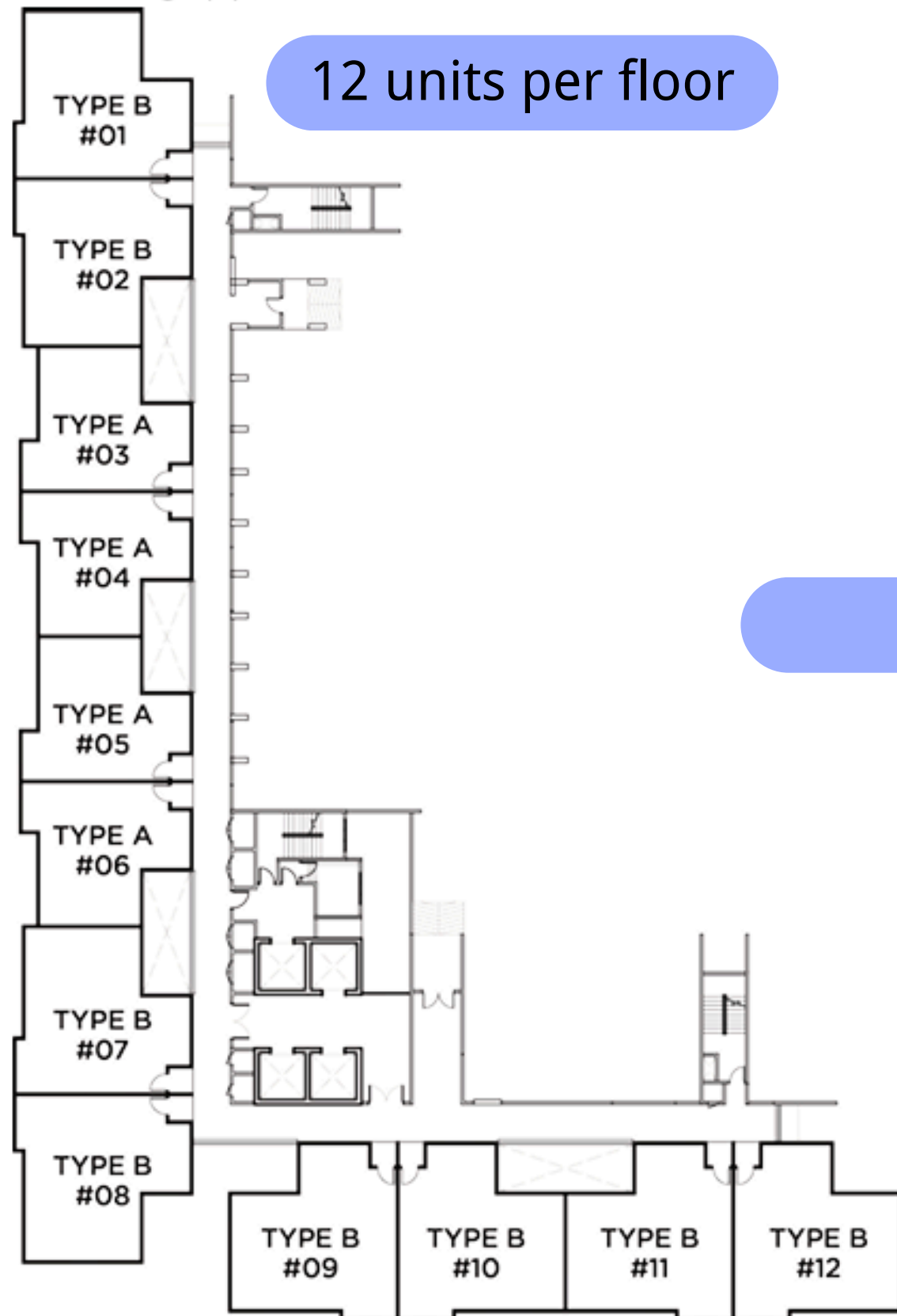

## TOWER B

11 units per floor

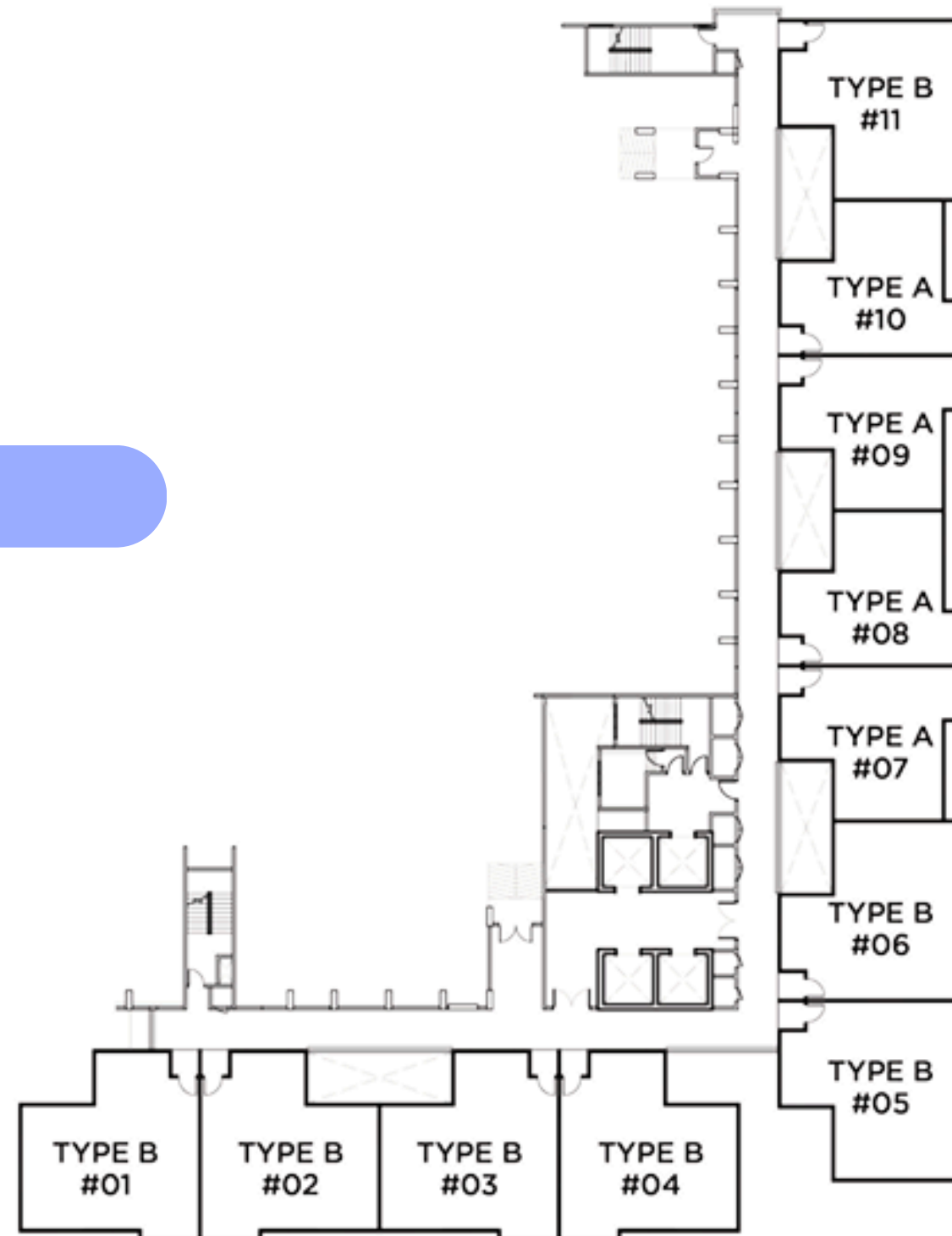

Carpark

# TYPICAL FLOOR PLAN

Level 7



SP SAM PROPERTY  
SDN BHD

## TOWER A

## TOWER B

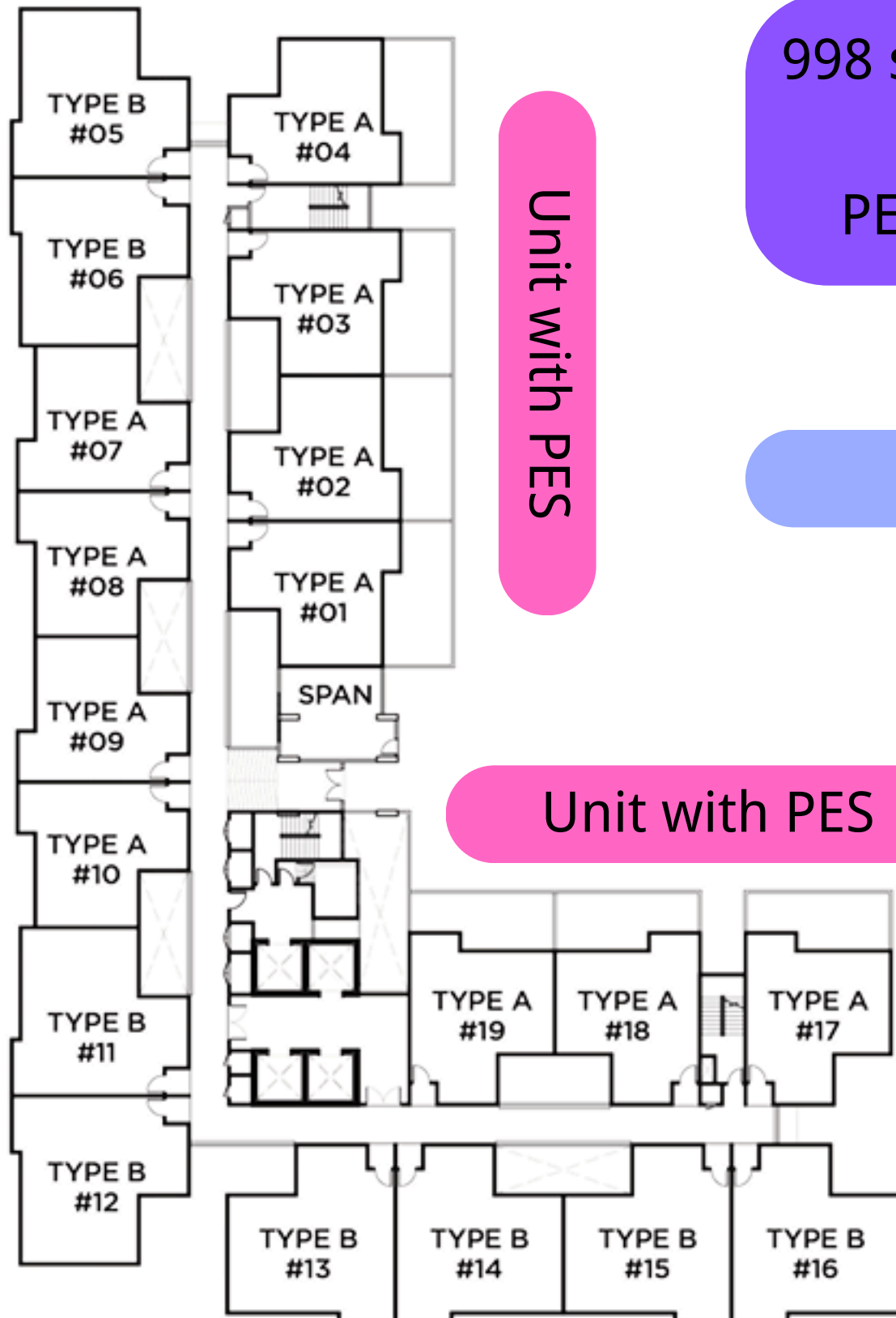

Unit with PES

Unit with PES

998 sqft - 658 sqft  
=  
PES 340 Sq Ft

Facilities

Unit with PES

Unit with PES

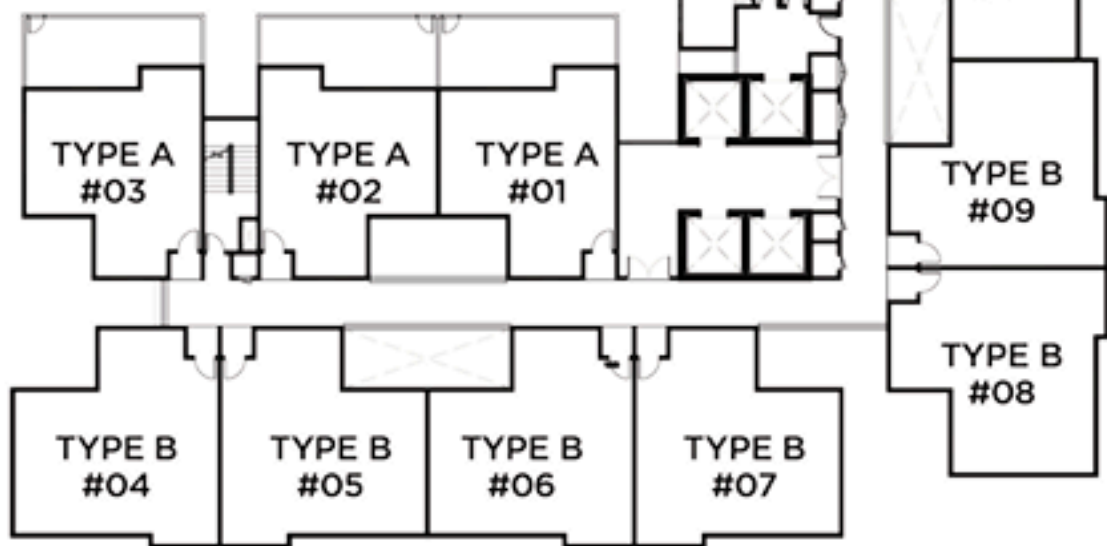

# TYPICAL UNIT PLAN

## TYPE A

- 1 + 1 Bedroom & 2 Bathrooms
- 685 sqft
- 583 units

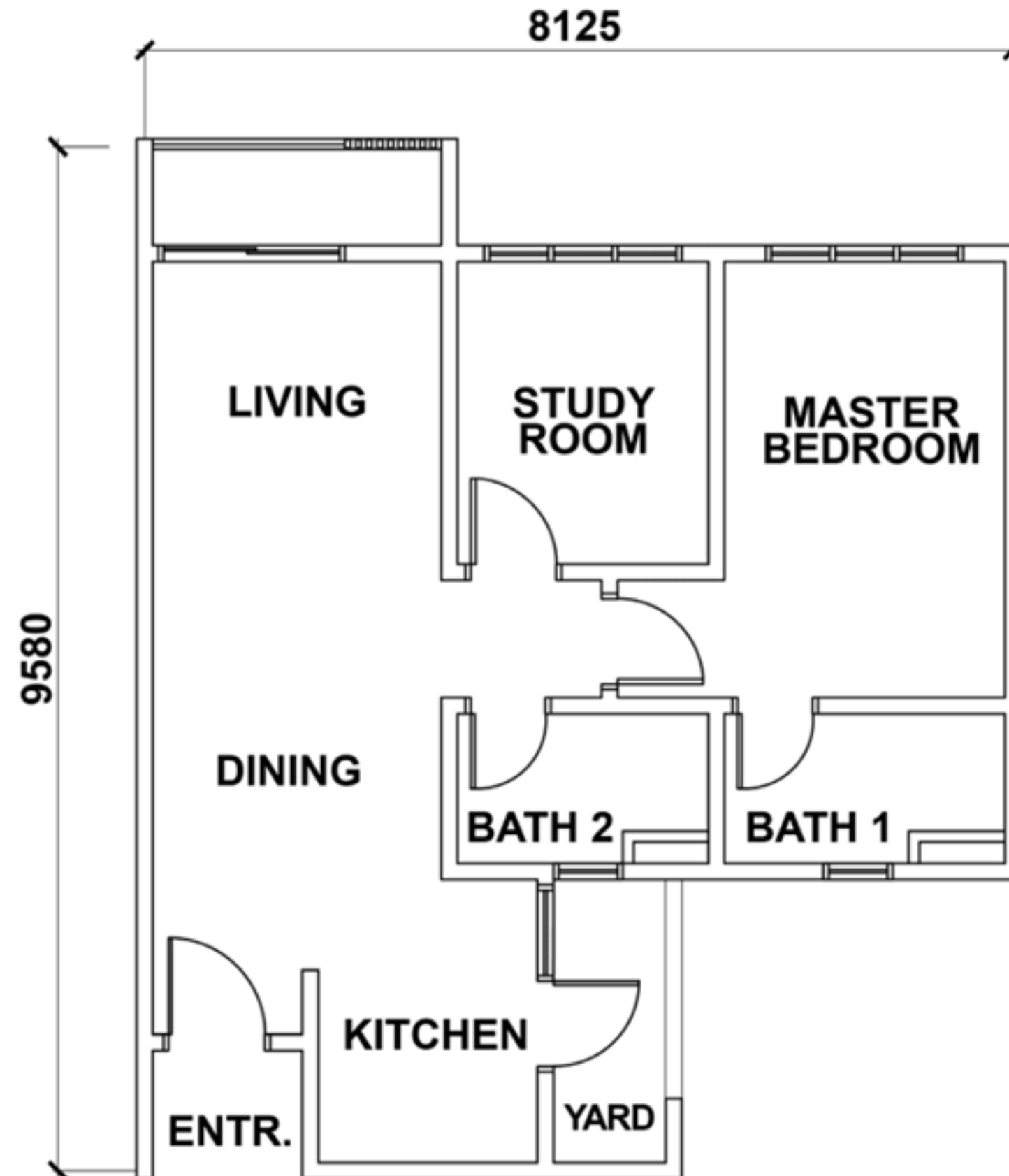

SP SAM PROPERTY  
SDN BHD



# TYPICAL UNIT PLAN

## TYPE A + PES

- 1+1 Bedroom & 2 Bathrooms
- 998 sqft
- 13 units

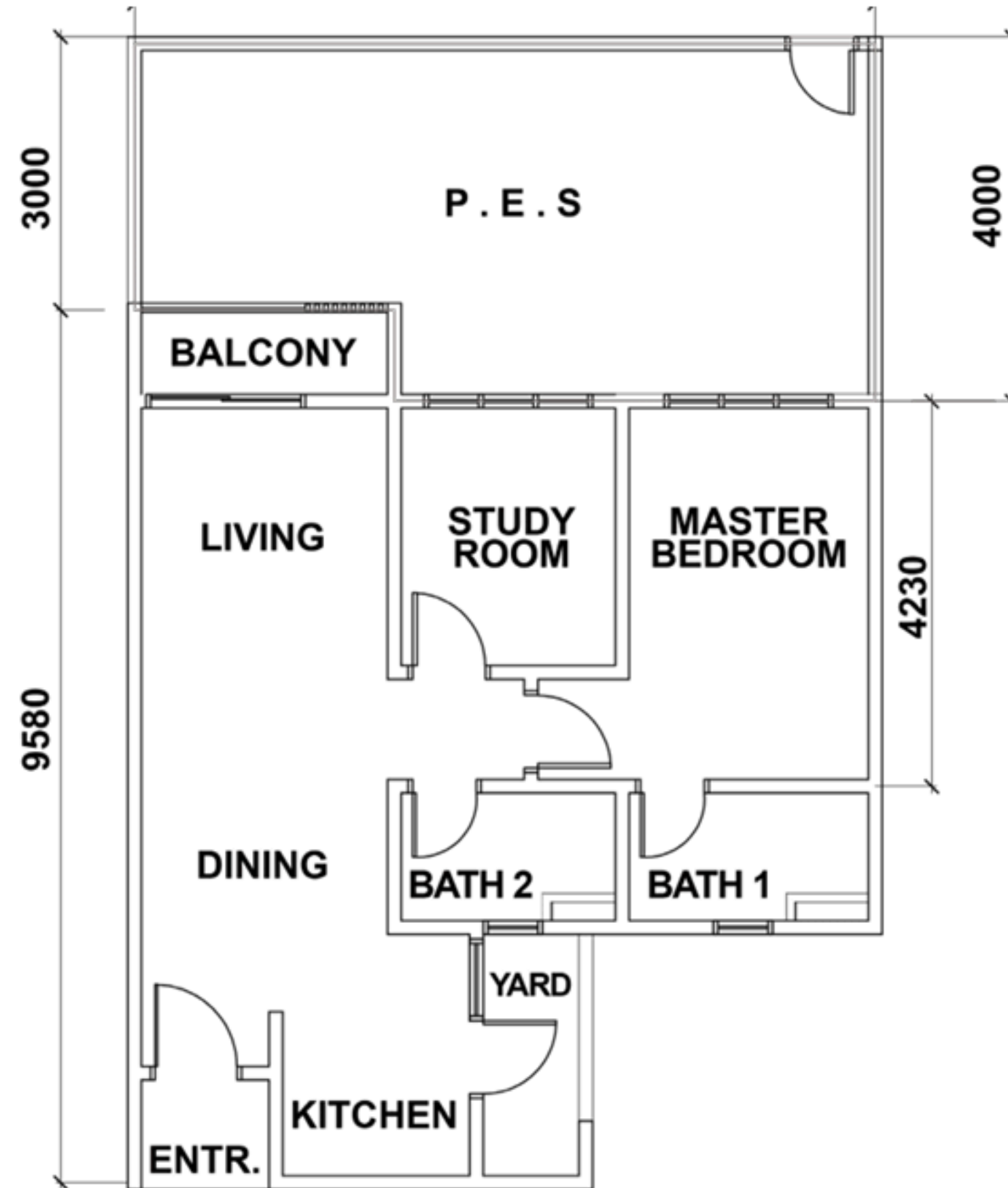

SP SAM PROPERTY  
SDN BHD

# TYPICAL UNIT PLAN

## TYPE B

- 3 Bedrooms & 2 Bathrooms
- 853 sqft
- 450 units

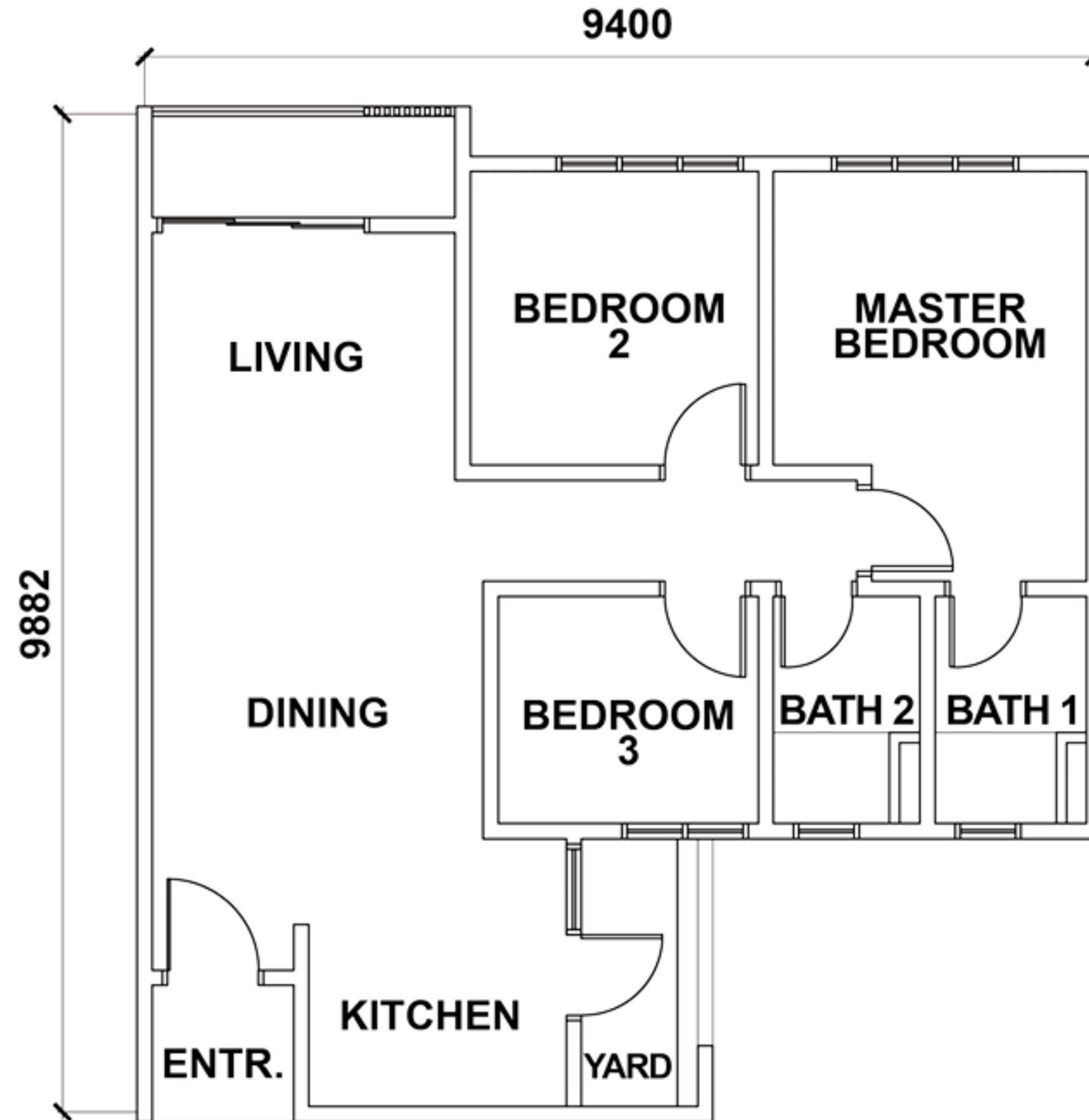

SP SAM PROPERTY  
SDN BHD



# Facilities



LEGENDS	
1	Futsal Half Court
2	Herbs Garden
3	Reflexology Path
4	Swimming Pool
5	Wading Pool
6	Gymnasium
7	Yoga Room
8	Multi-purpose Hall & Badminton Court
9	BBQ Pit
10	Playground
11	Outdoor Gym

# Package

- Rebate For Level 7th and above
  - Type A - 10%
  - Type B - 8%
- Rebate for Level 6th and below
  - Type A - 12%
  - Type B - 10%
- Foreigner eligible to purchase RM 400k and above
  - Foreigner Rebate 5%
- Free Legal Fee on SPA and LA
- Free Stamp Duty on LA
- Free Kitchen Cabinet and Cooking Hood & Hob
- Free Digital Lock

# Price

Type	Min Price	Min Price PSF
Type A 658 sq ft	RM 349,000	RM 530
Type B 853 sq ft	RM 418,500	RM 490



SP SAM PROPERTY  
SDN BHD

*Thank You*

---

